

Formsteel™



WORLD CLASS STEEL BUILDINGS SINCE 1972

**SVELTE®60
PRODUCT SPECIFICATION**

<https://formsteel.steelspec.co.nz>

SVELTE®60

MANUFACTURED TO THE LATEST NZ BUILDING STANDARDS MAKES IT EASY TO SPECIFY SVELTE®60 FOR MULTI-RISE PROJECTS.

Use the Composite Steel Decking online design tool
<https://formsteel.steelspec.co.nz>

Svelte®60 state-of-the-art profile has been developed using modern roll-forming techniques, finely crafted through our industry experience since 1972. An expertly engineered advanced composite steel floor system that's suitable for industrial, commercial & residential multi-storey buildings

Svelte®60 has been designed to provide excellent acoustic performance, fire protection and improved vibration softening properties. It also comes with pre-formed stop ends at the transition of floor and beam, to resist crack-forming sharp ends. This also helps assist with laying and blends into beams.

All our profiles are manufactured from the highest grade steel, and designed utilizing up to date design

standards including:

- AS/NZS 4600 "Cold formed structures code"
- AS/NZS2327:2017 Composite Structures - Composite Steel concrete construction in Buildings

Panels are manufactured from G550 (550MPa yield stress) steel with a base metal thickness of 0.75mm, 0.95mm and 1.15mm. The steel panel is protected with a galvanized coating of Z275.

Svelte®60 is delivered to site pre-cut to the correct sizes and ready to fix, reducing on site work. Cost effective & easy to install, Svelte®60 composite steel decking system delivers longer spans, requires less concrete, and ultimately drives down project cost.

SVELTE®60 PROFILE

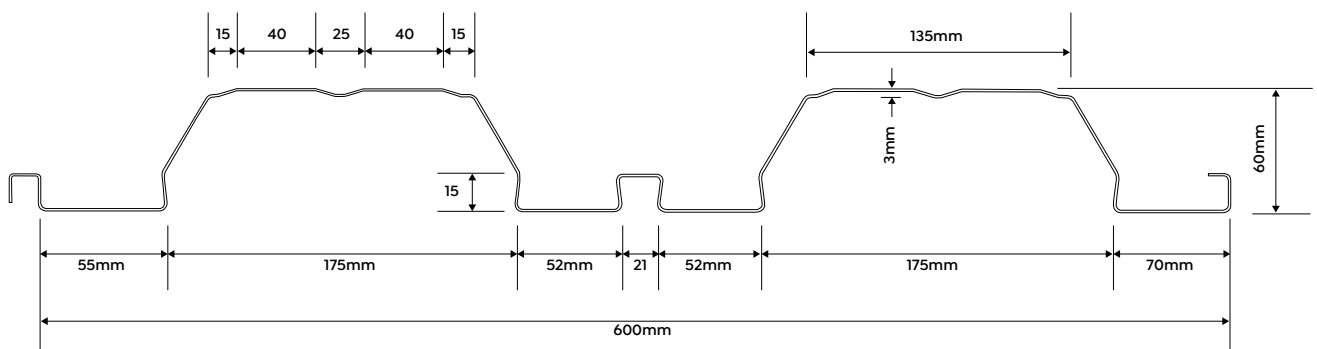

SVELTE®60 PROFILE & FEATURES

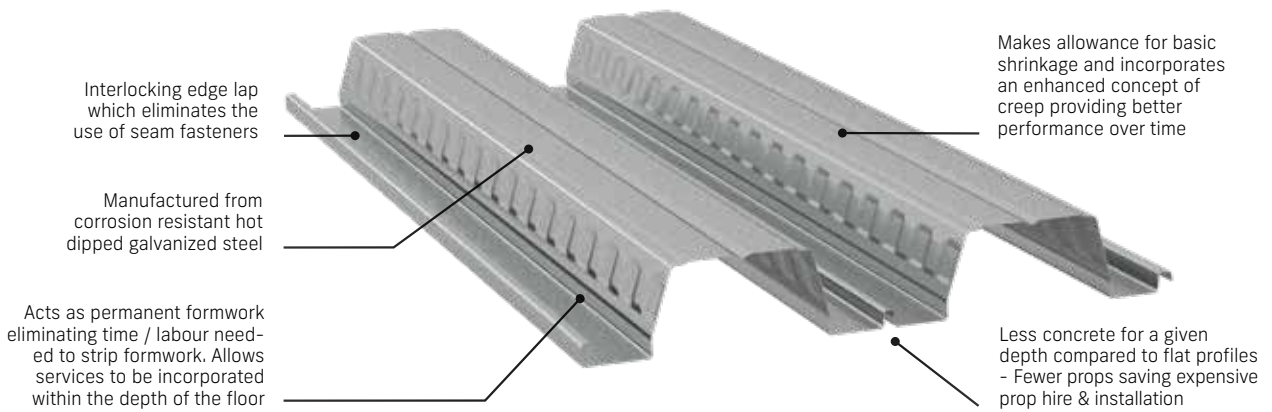

SVELTE®60 PRE-FORMED END

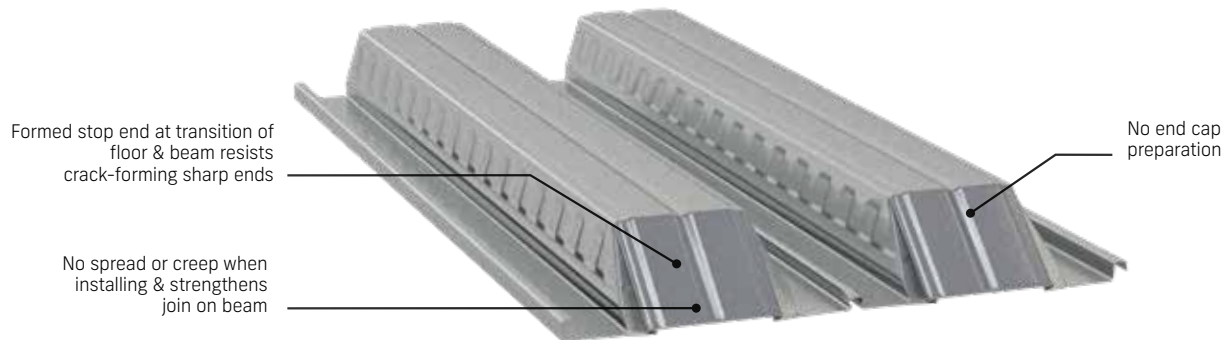

SVELTE®60 INSTALLED CROSS SECTION

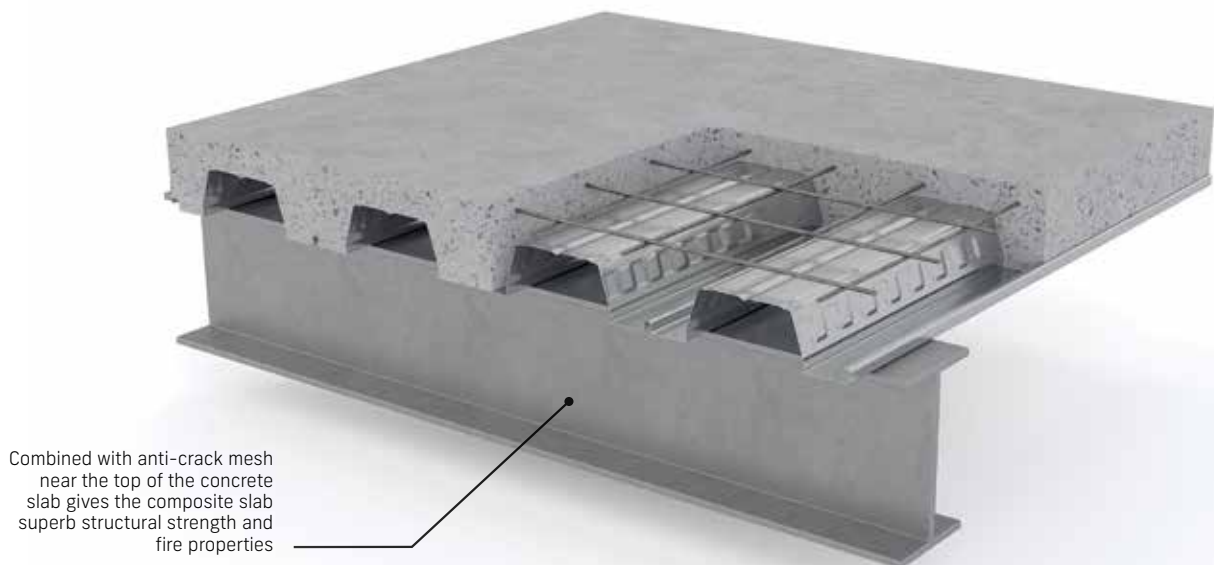

SVELTE®60 DESIGN NOTES

INTRODUCTION

SVELTE®60 has been engineered to offer the best in lightweight steel decking for multi-storey buildings. Highly popular and with excellent spanning abilities, it offers excellent shear bond performance. Delivered to site pre-cut to the correct sizes and ready to fix, reducing on site work. Cost effective & easy to install, SVELTE®60 composite steel decking system makes an excellent flooring solution for your projects. **Use the Composite Steel Decking online design tool: <https://formsteel.steel-spec.co.nz>**

LATEST TECHNICAL SPECIFICATIONS

As the last word in quality, Formsteel® composite tray decking systems apply the best of current technical thinking. This results in peerless performance, including:

- Enhanced shear performance due to deep embossing
- No rolling lube used to maintain concrete/steel bond
- Super concrete/steel indent in profile for superior bond
- Tested for concrete/steel bond and vibration, creep and shrinkage
- The formed stop end at the transition of floor and beam resists crack-forming sharp ends. It also assists laying and blends into beams
- All profiles 550mpa base steel strength
- 0.75, 0.95 are standard in G550. 1.15 special order G550 + 550.

LONG-SPAN CAPABILITY

The exceptional profile designs of SVELTE®60 deliver outstanding unpropped spanning capability and strength. Ultimately this helps to reduce both project structural steel requirements and costs. Design software is available to give unpropped double span options. Longer deck spans broaden beam spacing and reduce the number of the support beams, resulting in rapid erection and savings on the cost of the supporting steelwork

QUALITY & COST EFFICIENCIES

Formsteel's composite flooring solutions are designed to be adaptable, easy to install and cost-effective on any project. All our profiles are manufactured from

the highest grade steel, and designed utilizing up to date design standards including:

AS/NZS 4600 "Cold formed structures code"

AS/NZS 2327:2017 "Composite Structures

'Composite Steel concrete construction in Buildings"

Panels are manufactured from G550 (550MPa yield stress) steel with a base metal thickness of 0.752mm, 0.95mm & 1.15mm. The steel panel is protected with a galvanized coating of Z275. 1.15mm special order G550 + 550.

RELIABILITY & DEPENDABILITY

Our machinery is run by automated data controlled systems to make sure 100% accuracy and control across the manufacturing process. We also have capability to produce Pre-formed crushed ends using extra tooling connected to our machinery. Once the decking profiles are made, the product is packed with the sheet description. This ensures the smooth delivery of our products to site without mistakes. The sheets are carefully loaded and transported to site on time and to your exact specification. Our team are experts, and fully-trained to execute to the standards that you demand. Quality control check's, and regular maintenance of our production facility ensure that we stay on track to your brief.

SHEAR INTERACTION & PERFORMANCE

SVELTE®60 has enhanced shear performance due to deep embossment placed within webs. This guarantees shear stud positioning to optimise composite action,, reducing the requirement for on-site checking.

EXCELLENT ACOUSTIC & FIRE PERFORMANCE

Combined with Pre-Formed stop ends, SVELTE®60, gives superior fire protection and acoustic performance. Trapezoidal-floor has an inherent 30 minute FRR and requires no additional reinforcement at this rating. Fire designs are available for 60 min, 90 min, 120 min and 180 min FRR. Design live loadings used have been rationalized to 1.5 kPa, 3.0 kPa, 4.0 kPa and 5.0 kPa.



PRE-FORMED STOP ENDS

Factory formed stop ends for the trapezoidal flooring are both a practical and fiscal advantage. This innovative process negates the need for costly and time consuming site flashings, normally fitted to stop concrete flow back through rib profile. Formed during the cutting action in our factory these stop ends can be accurately matched to your site dimensions. Added benefits include, less or no concrete seepage at sheet ends, cost saving on supply and fitting of flashings, and creates a localised tapered thickening of concrete at sheet ends to give more integrated floor/beam strength. Hairline cracking!!!!!!

SAFE MANUAL HANDLING

SVELTE®60 is engineered to 600mm width sheets, is lightweight and easy to handle, which makes them a safer option, especially when working at heights.

SHRINKAGE CONSIDERATION

The degree of cracking will be determined in part by the amount of steel provided and the tensile stress within the negative reinforcement bars. Only shrinkage associate with restraint provided to concrete by the tray floor itself is considered in this brochure. Where the floor is supported on stiff walls advice is to be sought from Formsteel Industries Ltd.

CREEP INCORPORATION

Composite floor design uses the notion of transformed area and modular ratio to determine the combined member properties of the steel and concrete elements. Modular ratio values can vary between 8 and 26 depending on the nature and magnitude of loading.

DESIGN SOFTWARE TOOL - STEELSPEC™

Formsteel developed this tool so that Engineers are efficiently and quickly able to specify the right product. Steelspec™ has been designed to the latest standard AS/NZS2327:2017 Composite Structures – Composite Steel concrete construction in Buildings. A unique feature of the Steelspec™ tool, is the ability to optimise different solutions and provide you with the best suited design option. All designs are signed off by a Chartered Professional Engineer (CPEng).

REDUCED CONCRETE USAGE

The profile design of SVELTE®60 minimises the depth required for fire, acoustic and structural design. As this requires less concrete volume for slab depth, SVELTE®60 delivers a more sustainable & cost efficient solution through the reduction of concrete loads across all foundations and relating structures.

INSTALLATION Trapezoidal-floor is delivered to site pre-cut to the correct sizes ready to fix, reducing on site work. It acts as permanent formwork eliminating time and labour needed to strip formwork. The state-of-the-art profile has been developed using modern roll-forming techniques, drawing on our 20 years of experience in designing advanced composite floor systems. Engineered with a lower rib height SVELTE®60 provides excellent acoustic performance, fire protection and improved vibration dampening properties. Its profile has been specially designed with trough stiffeners and side laps positioned to guarantee centrally placed shear studs, ensuring the best possible stud performance. The cover is width is just 600mm, creating lightweight sheets that are easy to handle – delivering significant on-site safety benefits. SVELTE®60 has a wide range of applications, is fast to construct, lightweight, and provides a safe working platform so that the building process can continue without delay.